

NEURONAL SELECTIVITY WITHOUT INTERMEDIATE CELLS

Robert Pallbo

E-mail: robert.pallbo@fil.lu.se

*Lund University,
Cognitive Science,
Kungshuset, Lundagård,
S-223 50 Lund,
Sweden*

*Dept. of Computer Science,
Lund University,
Box 118,
S-221 00 Lund,
Sweden*

ABSTRACT

A model of orientation and direction selective cells is proposed. The dendritic connections of each cell are constructed with a local viewpoint. No consideration of the global function of the entire network is considered. Intermediate cells are not needed to make a cell selective, instead other cells with the same selectivity are used. The mechanism of the system is to update the previous activity rather than continually recreate selective detection. In the circuitry, spontaneous activity plays a functional role. This is needed for the circuitry to carry out initial detection of stimuli. The model allows a reduction of complexity in the circuits. In addition to a presentation of the models, two simulations implemented on computer are discussed.

1 INTRODUCTION

Models of neural circuitry are often inspired by finite automata, in the sense that the system constantly alters its state according to the information flow. However, the model to be presented here, is inspired by insect colonies as well as human interaction. Insect colonies are able to perform various types of behavior without any of the individual ants having an idea about what they are doing. The same is true, at least to some extent, in the interactions taking place in groups of humans. Of course, the individual must act in some predictable manner, otherwise there would be nothing but chaos. In every situation, there is some action that can be performed. For order to emerge, the individuals must use some, possibly unaware, strategy in the selection of actions.

In neural networks, there are two possible actions that each neuron can perform: either they fire or they do not. The choice of what action to perform must be determined by the activation pattern in the surrounding network. In this paper, a neuron will be viewed as an integrating component with both excitatory and inhibitory connec-

tions. I construct a strategy of each neuron and produce the behaviour in a network architecture.

If one were to choose an arbitrary neuron in the visual cortex and assume that its mission is to detect stimuli moving to the left: What would be the best strategy for this neuron? To find out, we need to take a closer look at the environment of the neuron.

1.1 SITES OF ACTIVITY

The neuronal activity caused by visual stimuli originates in the eye. A filtered image of the stimuli reaches the LGN from where it is further projected to the visual cortex. (See the appendix for details.) In 1962, Hubel and Wiesel discovered cells in the visual cortex that were selective for moving stimuli. Many of these cells were found to be selective to motion in only one direction. They labeled these as complex cells because their behaviour could not be explained solely on the basis of their projection from the LGN, but seemed to require intracortical connections. Other cells, were found to be selective for stationary stimuli with a certain orientation. These were labeled simple cells since this response could be

explained by connections to the LGN projection (Hubel & Wiesel, 1962). Later on, models involving more intracortical connections were suggested. However, all models make use of the projection from the LGN, and in what follows, it will be assumed that this is from where simple and complex cells receive their main excitation.

1.2 INTRACORTICAL CONNECTIONS

In addition to the connections with the LGN projection, simple and complex cells are supposed to have intracortical connections. These take the form of both excitatory as well as inhibitory connections (e.g., Douglas & Martin, 1991). It is believed, that excitatory connections are made mainly to other excitatory cells in the same functional group, for instance, cells tuned to horizontal bars connect to other horizontally tuned cells (Gilbert et al., 1990). The inhibitory connections, on the other hand, are supposed to be made to cells of opposite or null functionality, for instance, the horizontally tuned cells receive inhibitory connections from vertically tuned cells (Fester & Koch, 1987). Such intracortical connections are supposed to strengthen the selectivity of the cells.

1.3 CHEATING NEURONS

I will now return to the case of the arbitrary neuron and help it with a strategy. Because of the topological properties of the visual cortex, the neuron should only be active if there is enough activity in the corresponding LGN area. It does not need to be assumed that the connections with the LGN give rise to any selectivity. The first assumption is thus:

- (1) A simple or complex cell should not respond unless there is sufficient activity in the corresponding area in the LGN.

A second observation is as follows. Since the stimuli that the neuron is to detect are moving, there will be a prior response in other neurons if we assume that other neurons are responding as well to moving stimuli at a slightly shifted topological position. Therefore, we simply let the target neuron “sneak a look” at those, and this way, it will know when it is to respond. This second assumption completes the strategy:

- (2) A complex cell should await other cells that should respond slightly before the complex cell.

At first glance, this seems very farfetched. How is this supposed to work if all cells are “cheating” in this way, all trusting that the surrounding cells know exactly what they are doing? To explain this, we will make use of a

property of neural circuits sometimes referred to as noise.

1.4 SPONTANEOUS ACTIVITY

In opposition to most connectionist models, neurons in the cortex do not remain quiet when there is no obvious stimulus. Such discharges, termed spontaneous activity, take the form of stochastic, but not totally irregular, firing trains when recorded. This property can be observed in most of the cells in the cortex (Evarts, 1964). Since it is in this environment that the cells have developed and in which they operate, it is likely that this will affect the functionality, or in even stronger terms, that the functionality *depends* on spontaneous discharges.

To see what function the spontaneous activity can be, let us consider the problems associated with the strategy presented above. The strategy will work nicely if, and only if, the stimulus has already been detected. More clearly, the strategy above does not involve any initial detection of stimuli. This is because when a stimulus first appears, no neighbouring cells have been given a chance to respond and hence, no response will ever occur. This is the point where the spontaneous activity of cells is needed. Now and then, the neighbours will “falsely” respond to a non-present stimulus. In the case of an actually present stimulus, some cells will now and then give off a correct response. With some probability, these responses will be enough to affect the neighbours and bring them to respond. The signal will then transmit further and grow until it covers the entire stimulus projected from the LGN. In the case of a “false alarm” on the other hand, no stimulus will be present from the LGN, with the consequence that the response will fade quickly.

1.5 STRATEGY OF ORIENTATION SELECTIVITY

The situation is slightly different in the case of orientation selectivity. The strategy described above has to be revised in order to carry out this function. The first assumption is also valid for simple cells. These must as well preserve the topological properties of the visual cortex. The second assumption though, will not hold. Since the stimuli in these cases are stationary (assuming the entire scene to be stationary), there will be no cell signaling the forthcoming stimulus. Therefore, the strategy of a simple cell must be to await the response of the surrounding cells, and first thereafter respond itself, hoping that no one will notice the short delay. In short terms:

- (3) A simple cell awaits other simple cells of the same preferred orientation to respond, causing a short delay of the detection.

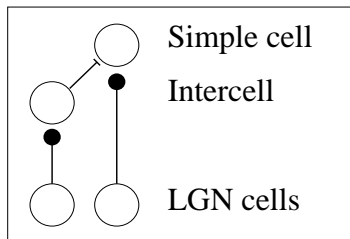

Fig 1. The model proposed by Heggelund (1981a).

Assuming that ignition occurs as above, with help from spontaneous discharges, the effect of the strategy will be that detection first occurs at the ignition point(s) and then spreads further to cover the entire stimulus projected from the LGN. That is, detection of orientation is not immediate according to this model. However, because of the speed of neuron operation, the short delay is not critical.

2 ORIENTATION SELECTIVITY

I will now discuss how the outlined strategy can be used in constructing a model. First a discussion on orientation selectivity is offered and thereafter direction selectivity.

2.1 RELATED WORK

In their paper from 1962, Hubel and Wiesel proposed that orientation selectivity arises from an elongated connective area in the LGN projection. (See the appendix.) Later, other models have been proposed (Fig. 1) (Heggelund, 1981a; Ferster & Koch, 1987). The model of Ferster & Koch, labeled cross-orientation, achieves most of the selectivity with inhibitory, intracortical connections. However, these connections, they assume, are insuffi-

cient to explain the selectivity. In their own words: “One cannot invoke orientation-specific neurons to explain the origin of orientation-specific neurons.” (page 488.) But this is actually exactly what I am suggesting! In the model proposed here, no orientation selectivity at all is supposed to originate from LGN connections.

2.2 SYNAPTIC CONNECTIONS

To achieve the selectivity, I will follow the strategy of the simple cells described above. According to (1), there must be connections to LGN terminals. As previously mentioned, these do not need to give rise to any selectivity. Therefore, we assume this field of connections to be circular (Fig. 2a).

Furthermore, according to (3), connections with other orientationally tuned cells are needed. These connections should be made with cells that are likely to respond simultaneously with this one. Therefore, in the case of vertically oriented cells, the connective field will have the outlook of Fig. 2b, while a horizontally tuned cell will have connections as in Fig. 2c.

Finally, inhibition must be present. If not, false ignitions on wrongly oriented stimuli will cause a response that does not recover until the corresponding LGN activity vanishes. The inhibitory connections originating from inhibitory cells will be discussed below. These are orientationally tuned as well. A simple cell should receive inhibition from other than the preferred orientation. The strongest inhibition should originate from null oriented cells. Since the inhibitory cells are supposed to be oriented, there is no reason for this connective field to be other than circular (Fig. 2d).

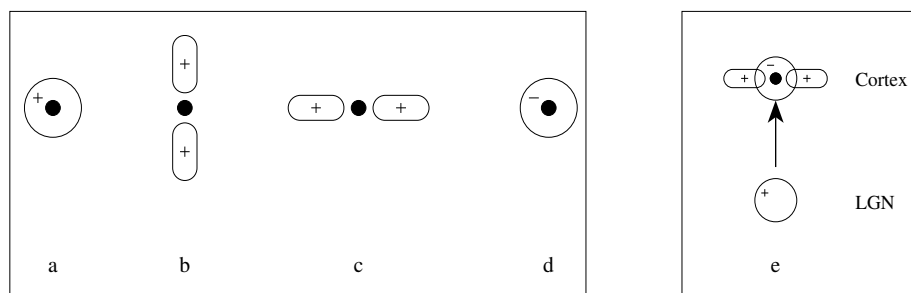

Fig 2. Connective fields of orientation selective cells from a view parallel to the cortical surface. The dots show the topographical position of the cell. (a) Excitatory connections to terminals of cells in the LGN. (b) Excitatory connections from other orientation selective cells, with preferred vertical orientation. (c) Same as b, with preferred horizontal orientation. (d) Field of connections from inhibitory cells. (e) A composition of the above showing a cell responsive to horizontal orientation. Refer to the text for details.

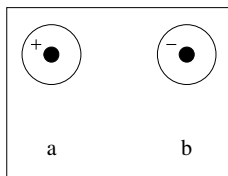

Fig 3. Inhibitory cells. (a) excitatory connections from cortical cells of the same preferred orientation. (b) Inhibitory connections with null oriented cells.

2.3 INHIBITORY CELLS

The cells responsible for the inhibitory connections are, as mentioned, assumed to be oriented. This feature is easily achieved in an environment of oriented *excitatory* cells. An inhibitory cell only needs to receive excitation from properly oriented cells in its topographical surroundings. That is, a circular connective field is assumed (Fig 3.a). In addition, connections to other inhibitory cells of other orientations must be made. This is to suppress possible false activity. Also, this area can be circular (Fig. 3b).

This is consistent with anatomical features of the synaptic symmetry of inhibitory cells (White, 1989 p: 43). The complexity of the model is limited to the excitatory intracortical connections of excitatory cells. All inhibition within the cortex, as well as the topographical projection from the LGN, are allowed to be symmetrical.

3 COMPUTER SIMULATION OF ORIENTATION SELECTIVITY

In order to evaluate the model, a simulation based on the model above was implemented on a computer. The details differ though from the theoretical work, and therefore a short description of the implemented model will be offered.

3.1 THE NEURON

I have used a model of the neuron that is similar to those used in connectionist networks. It is basically a threshold device including spontaneous activity and temporal summation. The internal state of a neuron is represented by a value reflecting the potential. A threshold is associated with the potential. If the value exceeds this threshold, the neuron will be considered active. At any given moment a neuron is either active or inactive corresponding to the external values one and zero respectively.

A weight is associated with each connection. To compute the present potential, all connected neurons are summed

using their external value multiplied with their weight. The previous potential of the neuron will also contribute to the present one by adding this value divided by a factor of two. This way, spatial as well as temporal summation is achieved.

When the potential reaches the threshold, the activity of the cell is reduced by the value of the threshold. One might expect the potential to be reset to zero. The reason it is not reset, is that I believe the effects of using discrete time is smoothed this way.

Irrespective of the potential, each cell is brought to activity by a given probability. This corresponds to the spontaneous discharge mentioned before.

3.2 THE CONNECTIONS

All connective fields are squares. In my default settings, the LGN field is 1×1 neuron, the excitatory cortical connective field is 1×7 , and the inhibitory connections is one-to-one. In this implementation, the inhibitory cells are wired the same way as the excitatory cells. It is unnecessary, however, to use inhibitory nodes in the simulation since the inhibitory neurons can achieve their orientation indirectly from their excitatory counterparts as mentioned before. This did not occur to me until after I wrote the simulator though. In any case, even if the implemented wiring is less biological realistic, the resulting functionality is the same, and therefore, the result of the simulation should not be affected.

3.3 DISCUSSION

There are several architectures that gives good selectivity. With strong asymmetric input from the LGN and a corresponding strong cross-inhibition, selectivity is achieved. However, the main connections in the visual cortex are excitatory, only 15% of cortical synapses are inhibitory (e.g., survey by Douglas & Martin, 1991). With symmetric input from the LGN, combined with intracortical asymmetric excitatory connections and cross-inhibition, as proposed in this paper, an equally good result is achieved. This is consistent with the findings that only about 20% of the excitatory connections in layer 4 come from thalamic terminals (Douglas & Martin, 1991).

4 DIRECTION SELECTIVITY

Two models of direction selectivity have been constructed. Only one of them has been tested in a computer simulation. The first one involves only excitatory connections. This is of course unbiological. The reason to construct such a model was to investigate the role of excitatory connections. The other model includes inhibi-

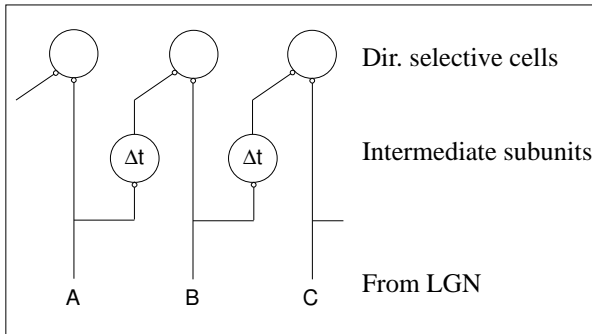

Fig 4. A model proposed by Barlow and Levick 1965. This is a model based on an excitatory mechanism. In addition, they also propose a model based on an inhibitory mechanism. Note the similarity to Heggelund's model of simple cells (Fig. 1).

tion and is more biologically accurate. In this section, I will concentrate on the inhibition-also model. In the next section, the excitation-only model as implemented on computer will be discussed. Before discussing those models, some models proposed by others should be considered.

4.1 RELATED WORKS

One of the first models proposed to carry out direction selectivity was that of Barlow and Levick (1965). This model was based on findings in rabbit's retinal cells. The ganglion cell was found to exhibit direction selectivity. The underlying circuit of this behavior was less clear however. In their paper, Barlow and Levick proposed two respective models based on excitatory and inhibitory mechanisms (Fig. 4). Both of these models make uses of intermediate subunits. These units delay the incoming signal which allows the direction selective cells to detect

temporal sequences. The subunits were not identified, but Barlow and Levick proposed that horizontal and amacrine cells perform this task.

Two schemes for local movement detection are usually separated in the literature, gradient- and correlation-type models (Borst & Egelhaaf, 1989; Ullman, 1983). The model of Fig. 4 is a correlation-type. Within these two classes of movement detection there is a broad variance. All schemes have in common that each node is a complete movement detector on its own. This is not the case with the model proposed in this paper. A neuron in this model is dependent on its surroundings. Moreover, the models proposed in this paper do not require intermediate units. This is because the network does not maintain the previous state of the input, but only requires the present state of selectivity which reflects the previous input. One could therefore say that the selective cells themselves take the character of intermediate cell.

4.2 SYNAPTIC CONNECTIONS

As with simple cells, connections should be made to LGN terminals (Fig. 5a). In addition, intracortical connections must be made. According to (2) above, there should be excitatory connections spreading to the null direction. This is because the cells located there will respond slightly before the target cell. In the case of a cell selective for motion from the left to the right we will get a field of connections as in Fig. 5b. In the case of downward motion, the corresponding area should have the outlook of Fig. 5c.

In opposition to the simple cell connecting to simple cells, as discussed above, the complex cell does not necessarily have to be exclusively connected to other complex cells (and the LGN). We can assume that they will be connected to simple cells as well. This causes the

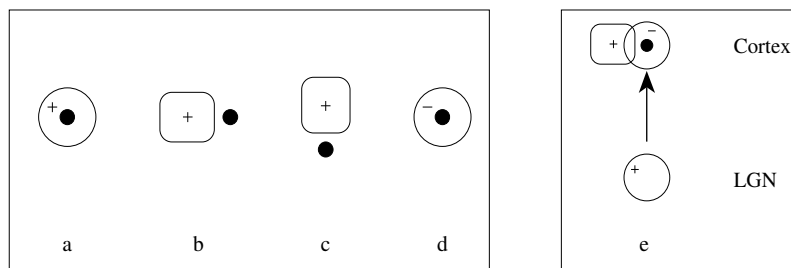

Fig 5. Connective fields of direction selective cells. The dots show the topographical position of the cell. (a) Excitatory connections from cells in the LGN. (b) Excitatory connections from *orientation* selective cells. Those cells should have the same orientation. This field belongs to a direction selective cell for motion from left to right. (c) Same as before, but with downward movement preferred. (d) Field of connections from inhibitory cells. The inhibitory cells themselves receive excitatory input from *directional* selective cells with areas as in a. (e) A composition of the above showing a cell responsive to left-to-right movement. Refer to the text for details.

complex cells to be orientationally tuned if the connected simple cells are of all the same orientation.

Regarding the inhibitory connections, these will come from direction selective cells. As in the case of simple cells, the connective field can be symmetric (Fig. 5c). Furthermore, these connections come from cells selective to the null direction.

4.3 INHIBITORY CELLS

In opposition to the direction selective *excitatory* cells, inhibitory cells are assumed to receive input from complex cells, not simple cells. This will make the inhibitory cells selective to direction and can therefore be used to suppress false ignitions. I will make the further assumption that the inhibitory cells also receive inputs from null directed inhibitory cells. The complex inhibitory cells are therefore constructed in the same manner as their simple cell counterparts.

5 COMPUTER SIMULATION OF DIRECTION SELECTIVITY

As mentioned, the simulated model is a strictly excitatory model. The interest in this simulation was to investigate to the extent to which excitatory connections could give rise to neuronal selectivity. In the case of direction selectivity, the circuit can make use of the fact that the stimulus to detect is in motion. In the case of a false ignition, stimuli will propagate in a wrong direction, and the false detection will quickly fade. This will also happen in the case of stationary stimuli. If the stimuli do not propagate in the correct direction, false ignitions will fade.

The stimulus used in the simulation, was a vertical bar, two input neurons in width. This bar could be made to propagate left, right or to be stationary.

5.1 THE NEURON

In this simulation, an even more simplified model of neurons are used than in the simulation of orientation selectivity. No temporal summation is made, and when a neuron fires, the internal potential is reset to zero at every time step. In other respects, there is no difference in the simulation used for orientation selectivity.

5.2 THE CONNECTIONS

The neurons that make up the primary input are not orientation selective, neither are the resulting direction selective neurons. Also, the intracortical connections do

not involve any simple cells in opposition to the model discussed in the previous section.

The connections to the input layer were made one-to-one. This field could be made larger as long as they are kept symmetrical (Fig. 6a). The purpose of this projection is to inform the direction selective neurons about the present visual input.

The only thing remaining, since no inhibition is involved, is the intracortical excitatory connections. These were discussed above. In the simulation, a square 5x4 (breadthxheight) is used as a default setting (Fig. 6b-c).

5.3 SIMULATION SETTINGS

In the setup, the threshold is set to 1000. The input connections are given a strength that is too weak to bring the potential over the threshold. To be activated, a neuron needs additional inputs from other direction selective neurons. This way, stationary stimuli are guaranteed not to cause any response. The number of additional required inputs depends on the size of the connective field of intracortical input. In one successful setting, I used a field 5x4 in size (breadthxheight), which means that it includes twenty neurons. To take the potential above the threshold, two neurons must be active in this field in addition to the simple cell. To achieve this, one might use the strength 930 to the simple cells and 40 to the directional selective cells. This setting guarantees that activation of a cell must always involve input from the projection. If this were not so, the neurons could start running wild and cause something like an epileptic seizure. This however, might be a risk worth considering if the probability of such a seizure is low.

5.4 RESULTS

When running the simulation, two characteristics of the stimuli seemed to be crucial for the function. These were the width of the stimulus bar and the speed of it. Both of

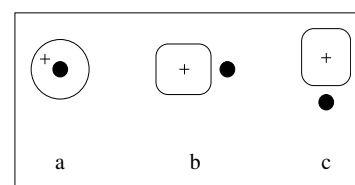

Fig 6. Connective fields of direction selective cells. The dots show the topographical position of the cell. (a) Excitatory connections to LGN cell terminals. (b) Excitatory connections to other direction selective cells. Preferred movement to the right, (c) Same as b, but with preferred movement downwards.

these features are related to the size of the *receptive* field of direction selective neurons.

The problem associated with width is that if the stimulus gets too wide, the network cannot distinguish stationary input from moving input. When the stimulus gets too wide the network makes many mistakes and responds to stationary input. It is crucial that stimulus is narrow enough to cover only a fraction of the receptive fields. Since this is the case in biological circuits where only the countours of an object is represented (see the appendix), we can ignore that problem here.

The problems of speed is as follows. When the stimulus moves slowly (propagating less than from one simple cell to another during one time step), then motion will be interpreted as stationary and will not give rise to any response. On the other hand, when the stimulus moves fast and only occurs once in the receptive field, the network cannot catch the motion. The problem arises from the fact that the detection must be continuous in the direction selective field. When the stimulus make steps bigger than the receptive fields, the continuity is lost. Therefore the size properties of the connective field of lateral connections in the cortex will determine the maximum speed that a neuron can respond to. One might think of having neurons with different receptive field properties to cope with various velocities.

6 DISCUSSION

The operation of this model is to update the previous activity rather than continually recreate selective detection. The problem associated with this is the appearance of a new stimulus. It is not sufficient just to update the previous activity at these occasions, some initial detection is needed. Since no such mechanism is involved in the outlined strategies, this detection must emerge somehow from the circuitry. The proposed feature giving rise to this is spontaneous activity. Since all neurons trust their neighbours, they may now and then be “tricked” into giving a false response, which, in some cases, will be a proper response. This is proposed to be the source of initial detection.

6.1 COMPLEXITY OF CONNECTIVE FIELDS

In the models proposed here, no intermediate neurons are used. This limits the complexity of the circuitry. More important though, is the complexity of the dendritic structure. The projection from the LGN to the visual cortex involves only symmetrical connections. Inhibitory cells receive input from a symmetrical area and inhibition to excitatory cells are symmetric as well. The only asymmetrical connections in the circuitry is the excita-

tory connections to excitatory cells. Hence, the only principal difference between orientation and direction selective cells lies in these connections. The benefit of such an arrangement is obvious: The mechanism of projection can be the same regardless of the function to be carried out. The inhibitory mechanism can also be the same. The only thing needed in order to construct a new functionality is to modify the excitatory connections, and, of course, the choice of the source to the input projection.

6.2 SCENE MOTION

In everyday life, the scenery projected on the visual cortex is not stationary. When the eyes are moved, because of a shift of attention or when tracking an object, the entire scene will move. If we return to the strategy metaphor, one could therefore expect a simple neuron to be connected to complex ones in order to get information about forthcoming stimuli. It is also likely that complex cells will receive input from both complex cells as well as simple cells as proposed above. The use of computer simulation might shed some light on such architectures.

6.3 SIMULATED ANNEALING

The spontaneous activity can be interpreted as energy that brings the system into stable activity states. This is not the same mechanism as simulated annealing though (Ackley et al., 1985), since the spontaneous activity is constantly kept at the same level. Locally though, the energy is less stable. This arrangement may not be completely beneficial, since in periods of high energy, a stable response might vanish, but this will only last temporarily.

6.4 SYNCHRONOUS FIRING

Because of the granularity of time in the computer simulation, it was not possible to examine the synchronous firing reported by Gray & Singer (1987; 1989), Gray et al. (1989), Eckhorn et al. (1988) and others. In theory though, this might be one possible effect of the intracortical connections. This would be caused by statement (2) and (3) stating that simple and complex cells await other cells before they fire. In that case, synchronous firing would be just an epiphenomenon of the circuitry in opposition to a mechanism of feature linking as suggested by Eckhorn et al. (1988).

6.5 FUTURE WORK

The models have so far been evaluated in the simulator described above. These models though, only offer one stimulus at a time. The models will therefore be evalu-

ated using video recordings of real scenes. These testings are already in preparation. Another area of interest is binocular vision. The strategies proposed for orientation and direction selectivity, might be possible to extend to this area. However, how the connections should be made in this case it not currently clear.

APPENDIX: THE VISUAL SYSTEM

A short description of the visual system is offered for those not familiar with vision. For further details please refer to the rich literature in this field (e.g., Hubel, 1988).

The rods and cones situated in the retina of the eye respond better as more light reaches them. This activity is further processed into an image similar to those of edge detection used in computer vision (Marr, 82). This filtering is carried out by the ganglion cells, which are also situated in the eye. The filter is constructed by using a bigger field of inhibitory connections and a smaller field of excitatory connections (or the invers) (cf the bottom part of Fig. 7).

The axons of the ganglion cells project to an area in the brain called the Lateral Geniculate Nucleus (LGN). This area has no known filter function but serves mainly to project binocular visual input to various sites, especially to the visual cortex. In the visual cortex, the cells are highly specialized, such as cells responding only to a bar shaped stimulus with a certain orientation, cells responding to certain direction or even cells responding to bars of certain lengths. (Cf. the bottom right of Fig. 7.)

FIELDS

In this paper, two distinct fields are used for describing a cell: The receptive field, an external classification of cells, and the connective field, a term used in this paper to describe connections.

Receptive fields: To classify visual cells, the notion of receptive fields is used. It is defined as the area in the visual field from which a response can be recorded from a selected cell. The receptive fields are smaller in or near the fovea, and get larger toward the periphery of the retina. In addition to the boundaries of the receptive fields, one can also determine the optimum stimulus of a cell. This is referred to as the receptive field properties of the cell. A preferred stimulus could be a bar shaped stimulus with a certain orientation positioned in the center of the receptive field. In Fig. 7, a selection of characteristic receptive field properties is shown at each site in the visual system.

Connective fields: The visual system preserves topological structure. This property can be used when describing the wiring of the system. This paper does not show any exact cell-to-cell connections. Instead a notion of connective fields is used. Such a field shows the topological area from where a cell receives an input. The area should be thought of as viewed from above the cortex, i.e., parallel to the surface. Consult Fig. 8 for a graphical explanation. The connective fields are not the same as the receptive fields, since those are defined from outside the system. The connective field is rather a pool of neurons from where the cell receives some of its input. What is

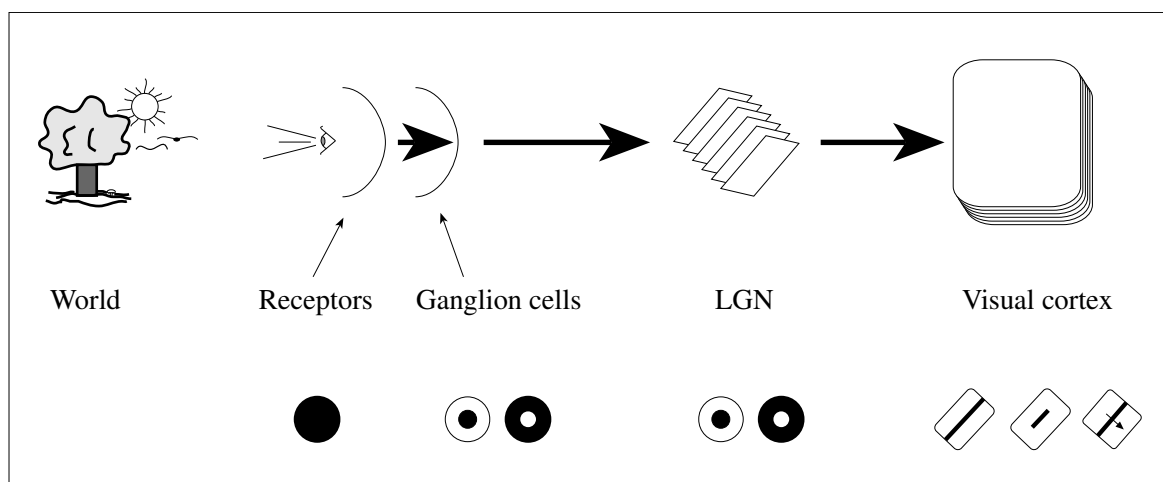

Fig 7. Principal organisation of the visual system. The receptors and the ganglion cells are both situated on the retina. The bottom figures show the receptive field properties of cells located in the corresponding area. It should be stressed that the LGN projects to other areas in the brain than the visual cortex. Another feature not shown is feedback from the visual cortex back to the LGN.

meant by the topological position of a cell is the center of the receptive field.

CELL CATEGORIES

The receptive field properties of cells discussed in this paper are described below. Note that there are subgroups not mentioned here in each category. The basic characteristics are the following (Hubel and Wiesel, 1962):

Ganglion cells: A dark area on an inverse background.

Simple cells: A bar with a certain orientation on an inverse background in the center of the receptive field.

Complex cells: A bar moving in a certain direction anywhere in the receptive field. The direction opposite to the preferred direction is called the null direction.

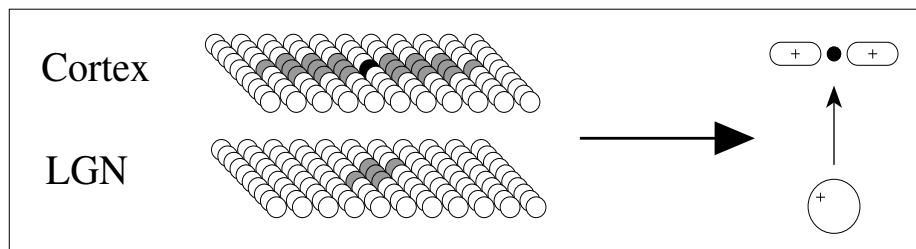

Fig 8. The topological structure of connective fields. To the left is shown an idealized drawing of the cortex and LGN. The black circle represents the node in focus. The gray circles are nodes from where the target node gets excitation. To the left, the node in focus is represented as a black dot. The connected nodes are not drawn. Instead, the topological form of the connected area is shown.

REFERENCES

- Ackley, D. H., Hinton, G. E. & Sejnowski, T. J., (1985), "A learning algorithm for Boltzmann machines", *Cognitive Science*, **9**, 147–169.
- Barlow, H. B. & Levick, W. R., (1965), "The mechanism of directionally selective units in rabbit's retina", *Journal of Physiology*, **178**, 477–504.
- Borst, A. & Egelhaaf, M., (1989), "Principles of visual motion detection", *Trends in neuroscience*, **12**, 297–306.
- Douglas, R. J. & Martin, K. A. C., (1991), "Opening the grey box", *Trends in Neuroscience*, **14**, 286–293.
- Eckhorn, R., Bauer, R., Jordan, W., Brosch, M., Kruse, W., Munk, M. & Reitboeck, H. J., (1988), "Coherent oscillations: A mechanism of feature linking in the visual cortex?", *Biological Cybernetics*, **60**, 121–130.
- Evarts, E. V., (1964), "Temporal patterns of discharge of pyramidal tract neurons during sleep and waking in the monkey", *Journal of Neurophysiology*, **27**, 152–171.
- Ferster, D. & Koch, C., (1987), "Neuronal connections underlying orientation selectivity in cat visual cortex", *Trends in Neuro Science*, **10**, 487–492.
- Gilbert, C. D., Hirsch, J. A. & Wiesel, T. N., (1990), "Lateral interactions in visual cortex", *Cold Spring Harbor Symposia on Quantitative Biology*, **50**, 663–677.
- Gray, C. M., König, P., Engel, A. K. & Singer, W., (1989), "Oscillatory responses in cat visual cortex exhibit inter-columnar synchronization which reflects global stimulus properties", *Nature*, **338**, 334–7.
- Gray, C. M. & Singer, W., (1987), "Stimulus-dependent neuronal oscillations in the cat visual cortex area 17", *Neuroscience*, **22** (suppl.), 1301P.
- Gray, C. M. & Singer, W., (1989), "Stimulus-specific oscillations in orientation columns of cat visual cortex", *Proc. Natl. Acad. Sci. USA*, **86**, 1698–1702.
- Heggelund, P., (1981a), "Receptive field organization of simple cells in cat striate cortex", *Experimental Brain Research*, **42**, 89–98.
- Heggelund, P., (1981b), "Receptive field organization of complex cells in cat striate cortex", *Experimental Brain Research*, **42**, 99–107.
- Hubel, D. H., (1982), "Exploration of the primary visual cortex, 1955–78", *Nature*, **299**, 515–524.
- Hubel, D. H., (1988), *Eye, brain, and vision*, Scientific American Library, New York.
- Hubel, D. H. & Wiesel, T. N., (1962), "Receptive fields, binocular interaction and functional architecture in the cat's visual cortex", *Journal of Physiology*, **160**, 106–154.
- Lippmann, R. P., (1987), "An introduction to computing with neural nets", *IEEE ASSP Magazine*, 4–22.
- Marr, D., (1982), *Vision*, W. H. Freeman and Company, New York.
- Ullman, S., (1983), "The measurement of visual motion: Computational considerations and some neurophysiological implications", *Trends in Neuroscience*, **6**, 177–179.
- White, E. L., (1989), *Cortical circuits*, Birkhäuser, Boston.